



ZONA DE INTERVENTIE



ROMANIA
 BENEZICENTOR
 NUME: CERCELA
 PRENUMARE: CONSTANTIN PLODIN
 SEMNATURA
 CEN/AN/ST. DT.
 17.11.2019, B2, 02
 ALINA G. CECILIA
 DIRECTOR NR. 400
 BENEFICIAR:

J.C. SINTERUL NAVAL DAMEN GALATI S.A

DENUMIRE PROIECT:
 CONSOLIDARE DRUM
 TEHNOLOGIC IN
 LUNGUL CHEIULUI, ZONA
 DANA 1, 2 SI 3

PROIECTANT:
S.C. SERVLAND S.R.L.

SEF PROIECT **SEMNATURA**
SERVLAND S.R.L.
 Dr. Ing. Octavian Eugenii
 SEMNATURA
 PROIECTAT SEMNATURA
 Ing. Alin Vasile-Alexandru
 DESENAT SEMNATURA
 Ing. Alin Vasile-Alexandru

DENUMIRE PLANSĂ:

PLAN DE ÎNCADRARE ÎN TERITORIU

PROIECT NR.: 24/2018

FAZA: P.A.C.

NR. PLANSĂ: PL.1.0

SCARA: 1:2500

DATA: 2019

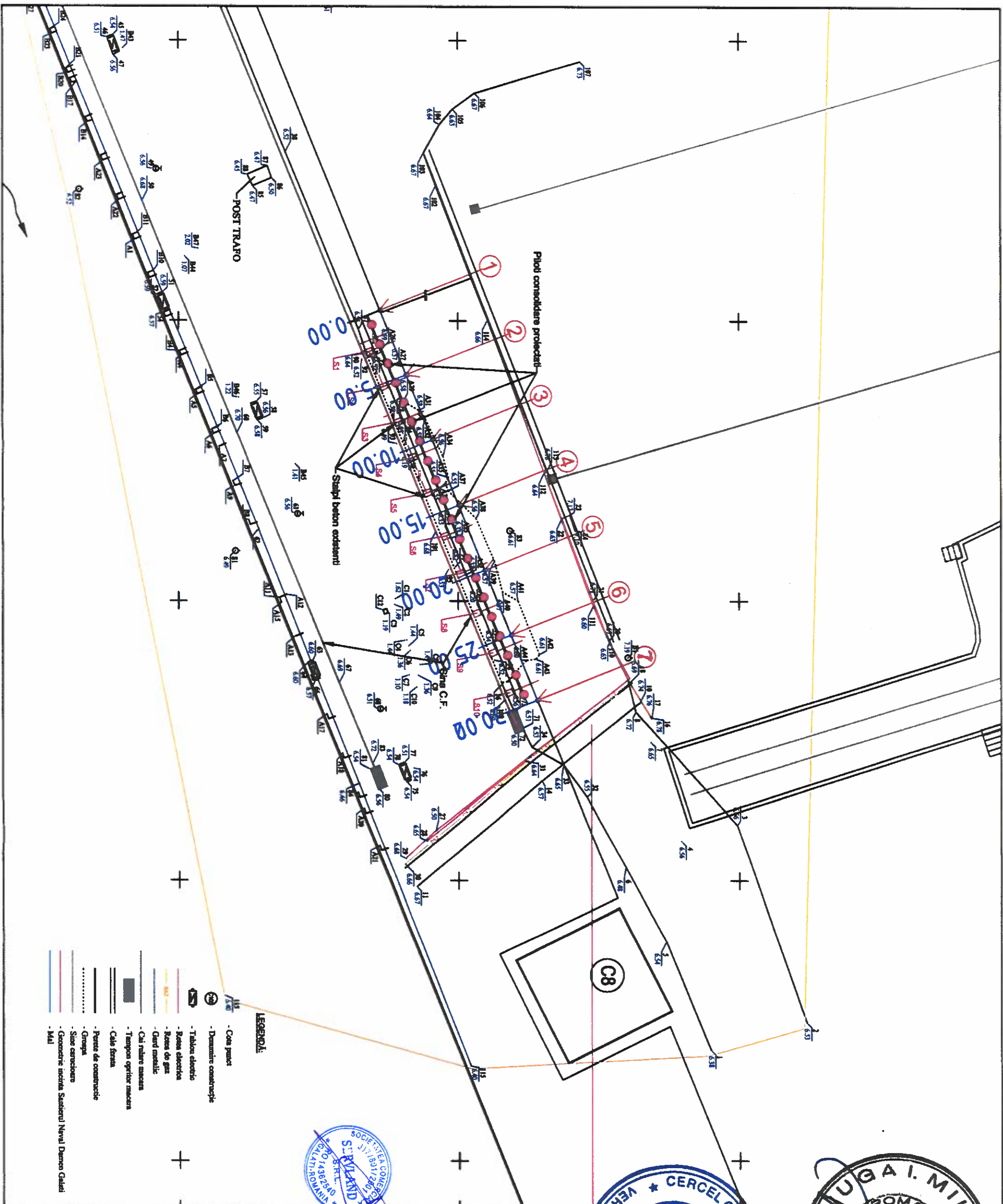

- LEGENDA:**
- Piloni proiectati
 - Structuri beton castanteni
 - Distribuitor constructie
 - Tabele electrice
 - Baze electrice
 - Baza de gaz
 - Canal metalic
 - Cai retele sanare
 - Tampone operator sanare
 - Cale ferre
 - Perete de constructie
 - Grampa
 - Stare constructie
 - Geometrie incinta Santerul Naval Damen Galati
 - MAI

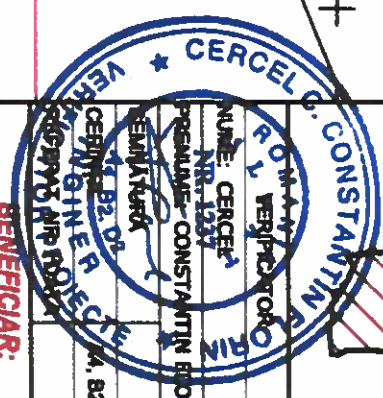

PROIECTANT: S.C. SERVLAND S.R.L. Sediul: Strada George Emil, Nr. 10, Galati Județul Galati Inregistrare CF: 1436354		BENEFICIAR: S.C. SANTERUL NAVAL DAMEN GALATI S.A.	
DENUMIRE PROIECT: CONSOLIDARE DRUM TEHNOLOGIC IN LUNGUL CHEIULUI, ZONA DANA 1, 2 SI 3		VERIFICATORI: NUME: CERCELA NR. 1231 PRENUME: CONSTANTIN BORIN SEMNTURA: CERCELA VERIFICATORI Str. 12 Septembrie, Nr. 82, D2 CERCEALA, IALOVA	
SEF PROIECT: Dr. Ing. Octavian Eugen		SEMNTURA:	
PROIECTAT: Ing. Mircea Vas-Alexandru		SEMNTURA:	
DESEINAT: Ing. Mircea Vas-Alexandru		SEMNTURA:	
PLAN DE SITUATIE			
PROIECT NR.: 24/2018			
FAZA: P.A.C.			
NR. PLANSA: PL. 2.0			
SCARA: 1:250			
DATA: 2019			

Profil transversal TIP Nr. 1

Platforma drumului

Parte carosabilă

variabil 7,90 - 7,40

2,00%

2,00%

4,00%

4,00%

- Structură Rutieră proiectată:**
- Strat de uzură: BcR4, h = 20,00 cm
- Strat izolant: nisip + harde Krafi, h = 2,00 cm
- Strat de fundație: balast, h = 120,00 cm
- Geotextil cu rol filtrant

Dop mixtură
BA16
100

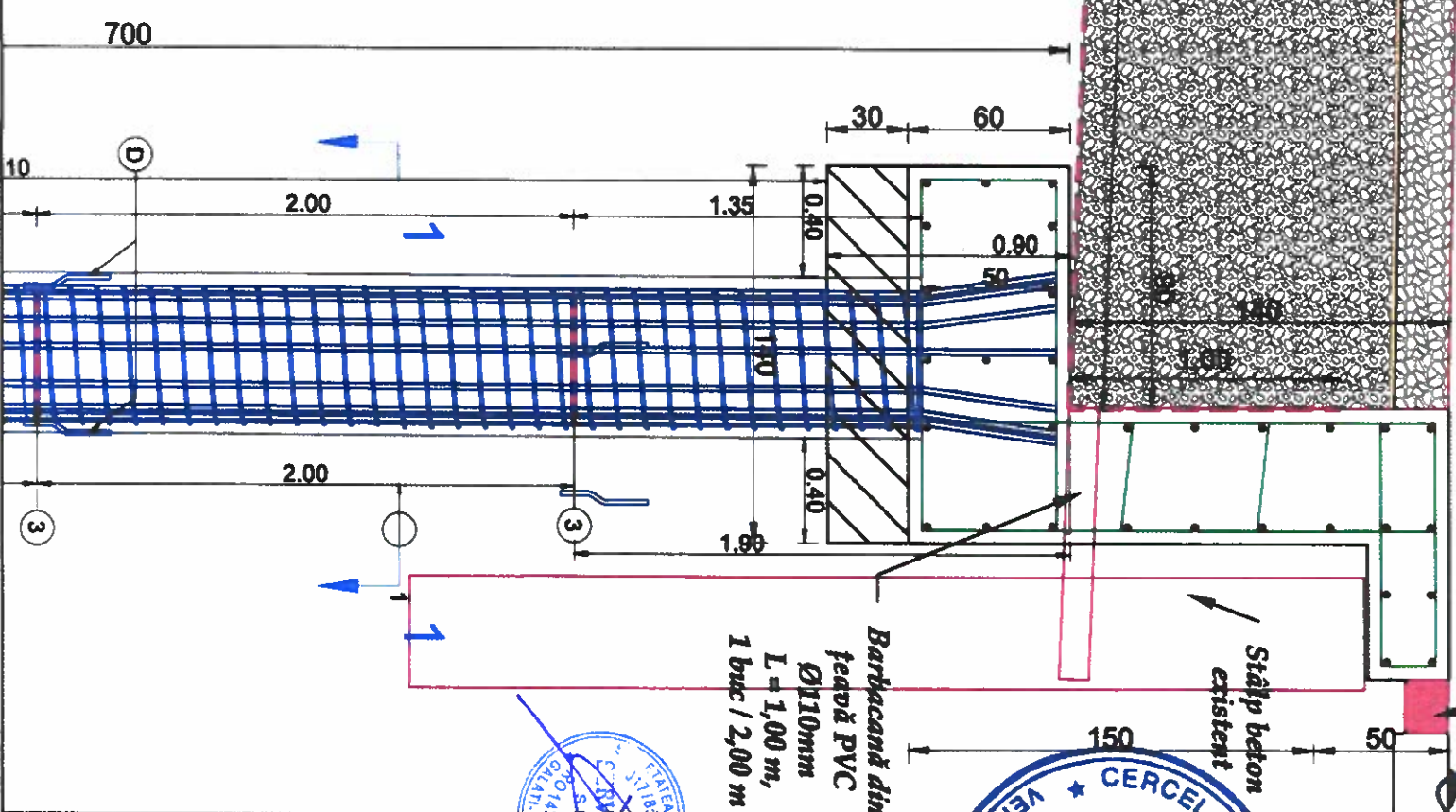

VERIFICATOR
NUME: CERCEL
PRENOM: CONSTANTIN FLORIN
SEMNAȚURA
CERȘIN ANINA
AȘESRAT NR./PALT
NR. BENEFICIAR:
INGINER PROIECT

CONSOLIDARE DRUM
TEHNOLOGIC IN
LUNGUL CHEBULUI, ZONA
DANA 1, 2 SI 3

PROIECTANT:
S.C. SERVLAND S.R.L.

PROIECTANT	SEMNAȚURA
DESIGNAT	SEMNAȚURA
PROIECT NR.:	24/2018
FAZA:	P.A.C.
NR. PLANȘA:	PL. 3.0
SCARA:	1:250
DATA:	2019

Cota Ref. -3.90

RACORDARI VERTICALE	L=30.016						P=0.00%					
COTE PROJECT-LINE ROSIE	6.55	6.55	6.55	6.55	6.55	6.55						
COTE TEREN	6.59	6.59	6.56	6.48	6.57	6.59						
COTE FUNDARE ZID	4.23	4.23	4.23	4.23	4.24	4.24						
COTE FUNDARE PILOTI	-1.87	-1.87	-1.87	-1.86	-1.86	-1.86						
Număr Secțiune	1	2	3	4	5	6						
DISTANTE CUMULATE	0.00	5.00	10.00	15.00	20.00	25.00						
							30.00					
							30.02					

PROFIL LONGITUDINAL LIM PLATF DE LA 0.000 LA 30.018 SCARA : ORIZ 1 :500 VERT 1 :100

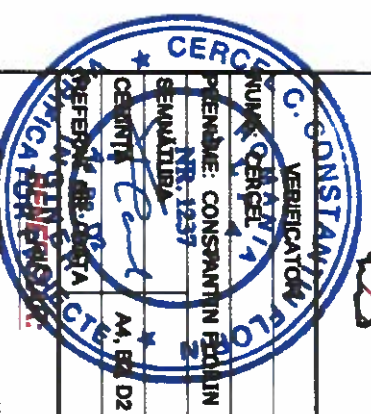
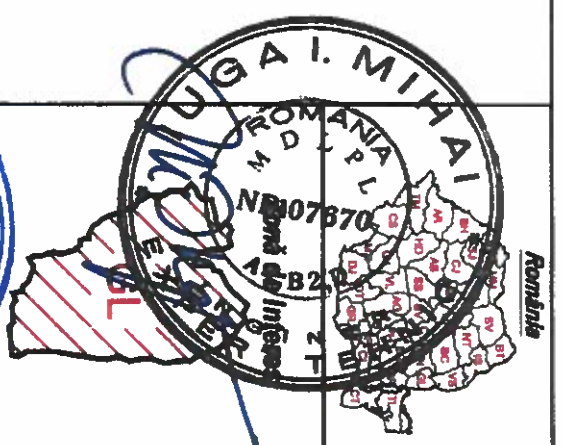

S.C. LANTERUL NAVAL
DAMEN GALATI S.A

DENUMIRE PROIECT:
CONSOLIDARE DRUM
TEHNOLOGIC IN
LUNGUL CHEBULUI, ZONA
DANA 1, 2 SI 3

PROIECTANT:
S.C. SERVLAND S.R.L.

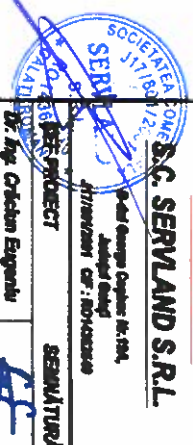

PROIECTANT: SEMNATURAL
Ing. Ilieșu Vasile-Alexandru
DESENAT: SEMNATURAL
Ing. Ilieșu Vasile-Alexandru

DENUMIRE PLANȘĂ:
PROFIL
LONGITUDINAL

PROIECT NR.: 24/2018
FAZA: P.A.C.
NR. PLANȘĂ: PL. 4.0
SCARA: 1:500/1:100
DATA: 2019

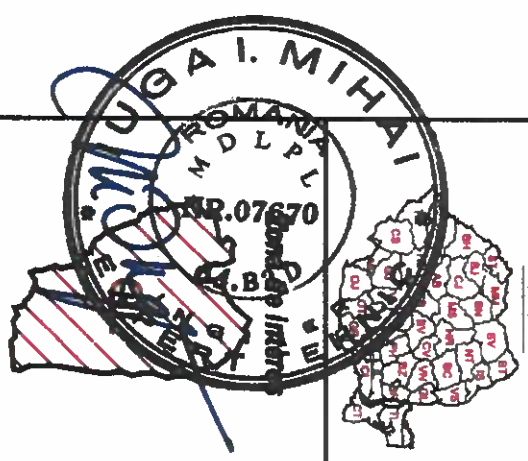

VERIFICATOR

NUME: CERCEL

ING. CERNESCU CONSTANTIN FLORIN

SEMANTURĂ

Școala nr. 4, data

Școala nr. 4, data

Școala nr. 4, data

Școala nr. 4, data

Școala nr. 4, data

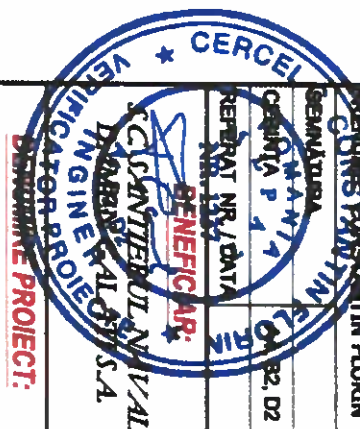

CONSOLIDARE DRUM
TEHNOLOGIC IN
LUNGUL CHEULUI, ZONA
DANA 1, 2 SI 3

PROIECTANT:

S.C. SERVLAND S.R.L.

Societate cu Capital Privat

RO 143625

Școala nr. 4, data

Școala nr. 4, data

Școala nr. 4, data

Școala nr. 4, data

Școala nr. 4, data

Școala nr. 4, data

Școala nr. 4, data

Școala nr. 4, data

Școala nr. 4, data

Școala nr. 4, data

Școala nr. 4, data

Școala nr. 4, data

Școala nr. 4, data

Școala nr. 4, data

Școala nr. 4, data

Școala nr. 4, data

Școala nr. 4, data

Școala nr. 4, data

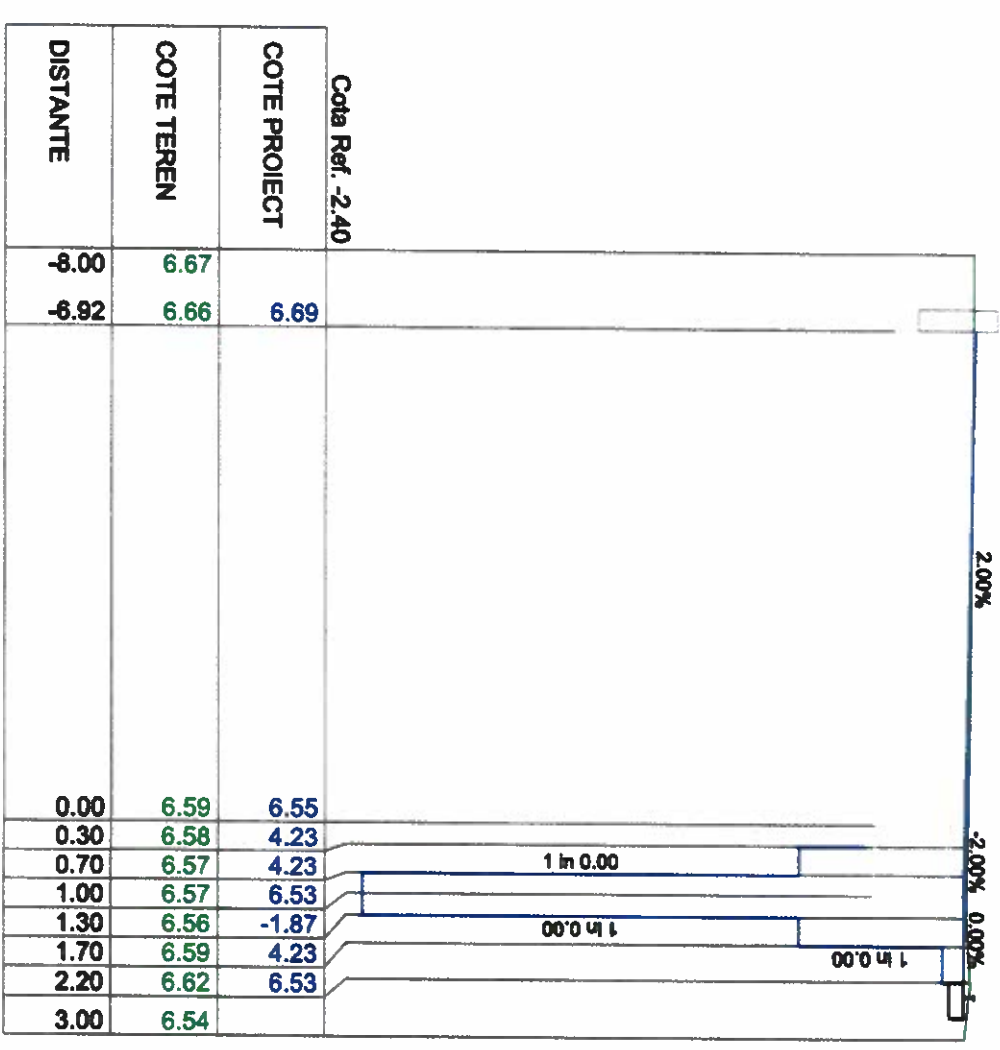
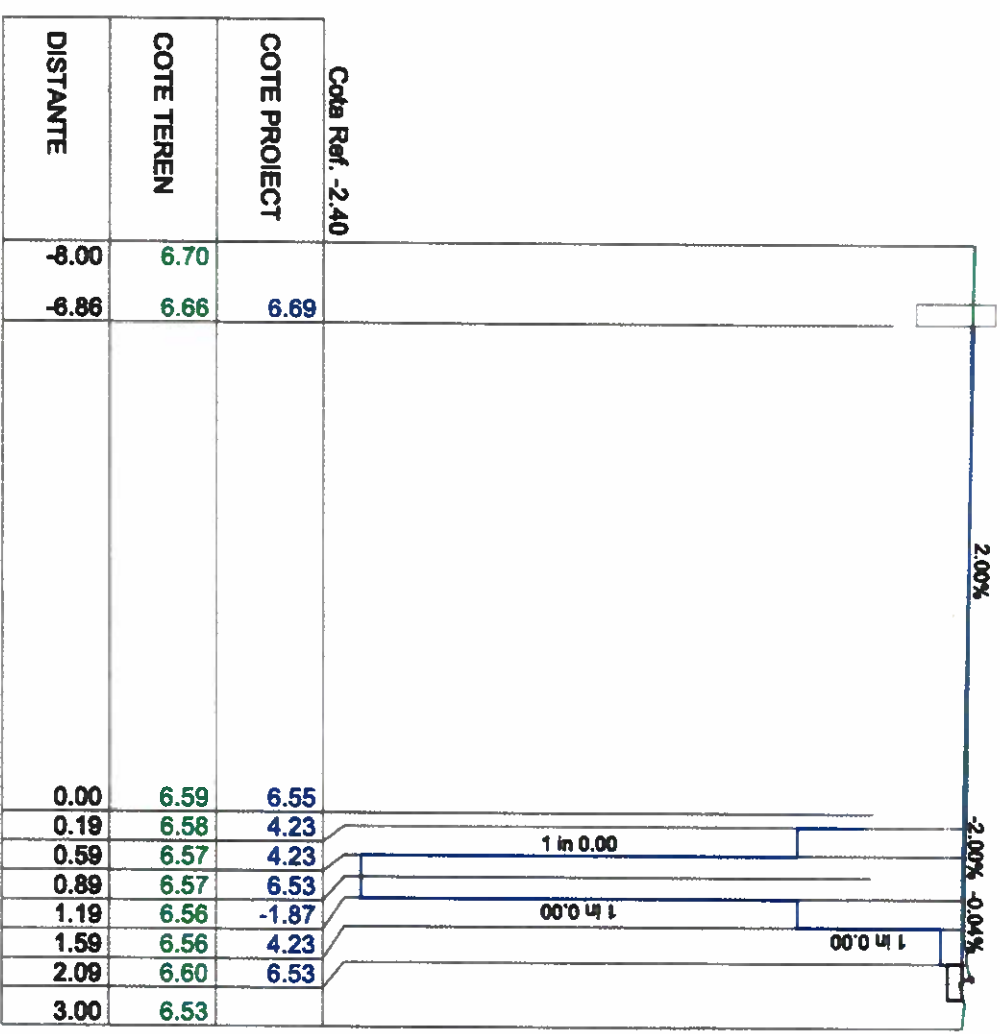

PROIECT NR.:	24/2018
FAZA:	P.A.C.
NR. PLANȘĂ:	PL. 5.0
SCARA:	1:100
DATA:	2019

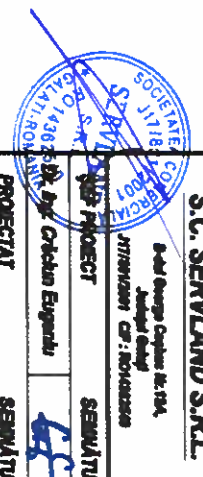
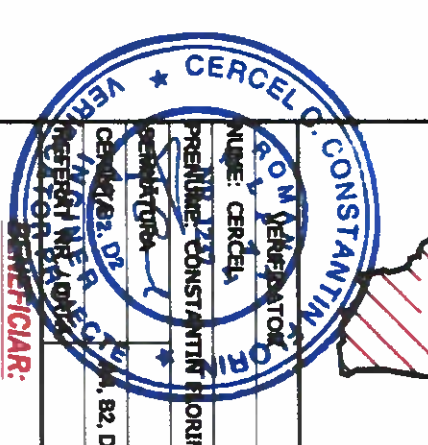
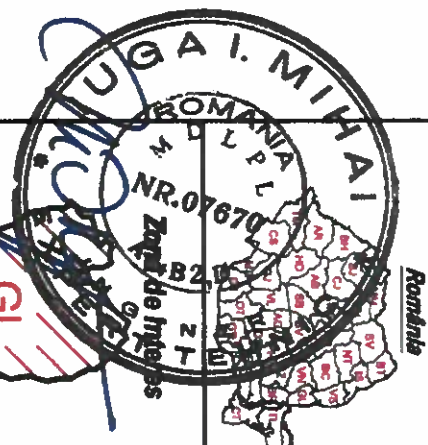
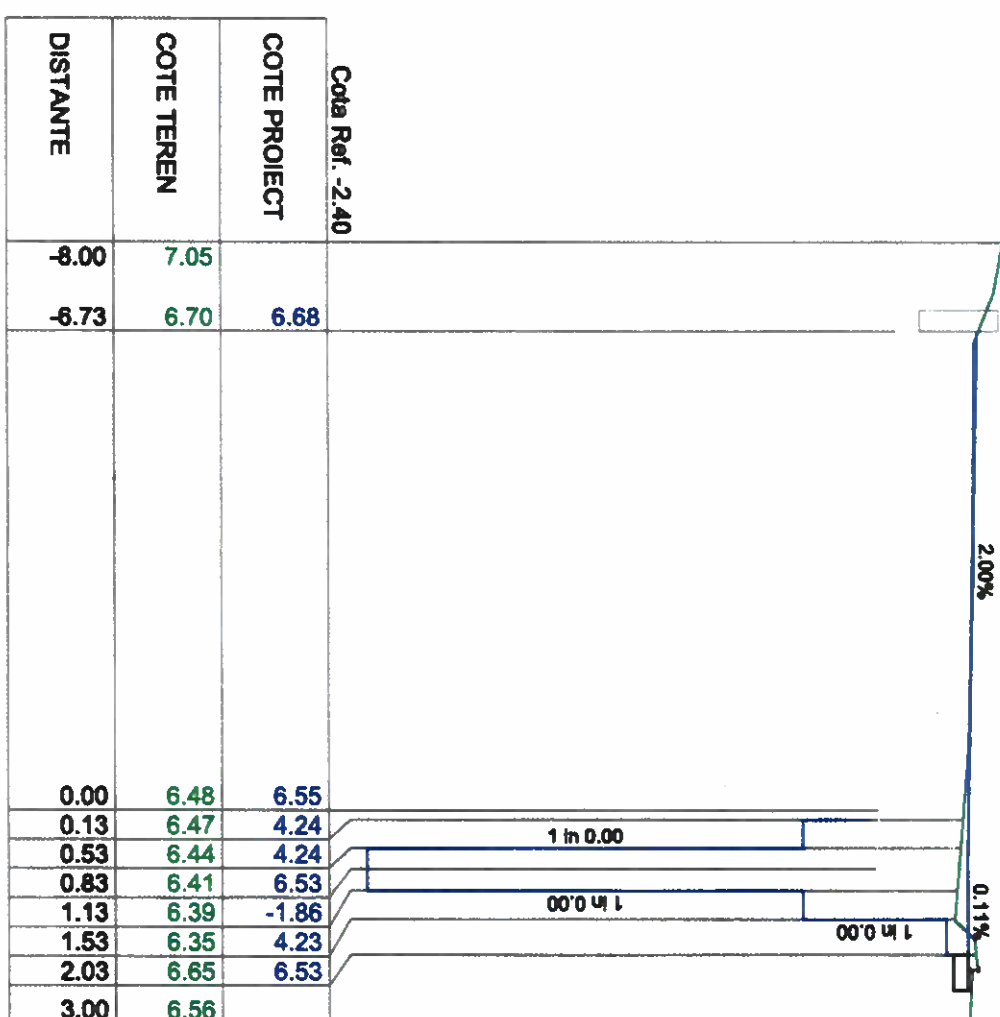
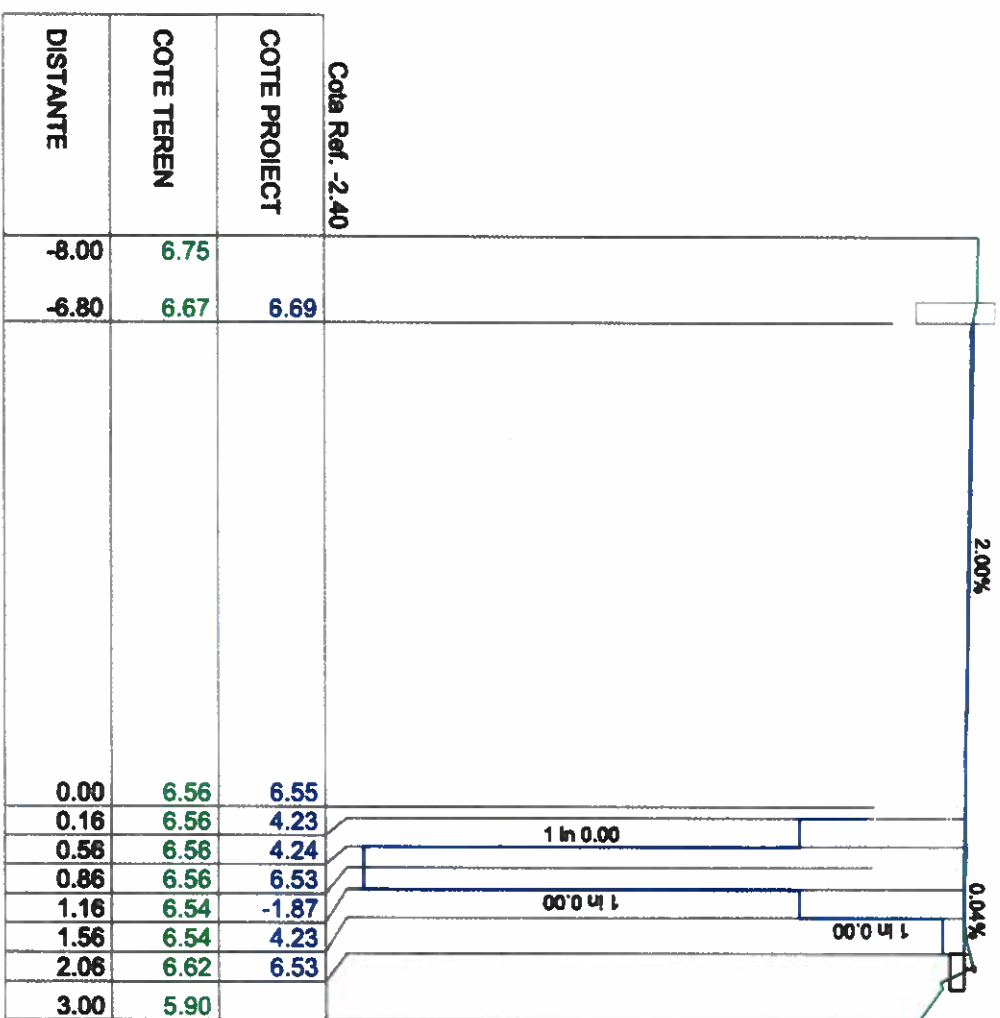

PROIECTANT:
S.C. SERVLAND S.R.L.
București, Căminul nr. 104
Strada nr. 104
Județul Ilfov

DENUMIRE PROIECT:
CONSOLIDARE DRUM
TEHNOLOGIC IN
LUNGUL CHEULUI, ZONA
DANA 1, 2 SI 3

PROIECTAT
Ing. Marius Vlad-Alexandru
SEMĂTURĂ

DESENAT
Ing. Marius Vlad-Alexandru
SEMĂTURĂ

DENUMIRE PLANȘĂ:
PROFILE
TRANSVERSARE
CARACTERISTICE

PROIECT NR.: 24/2018

FAZA: P.A.C.

NR. PLANȘĂ: PL. 5.1

SCARA: 1:100

DATA: 2019

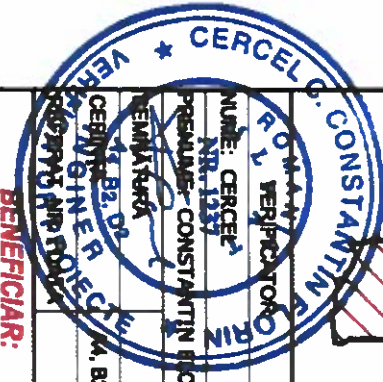
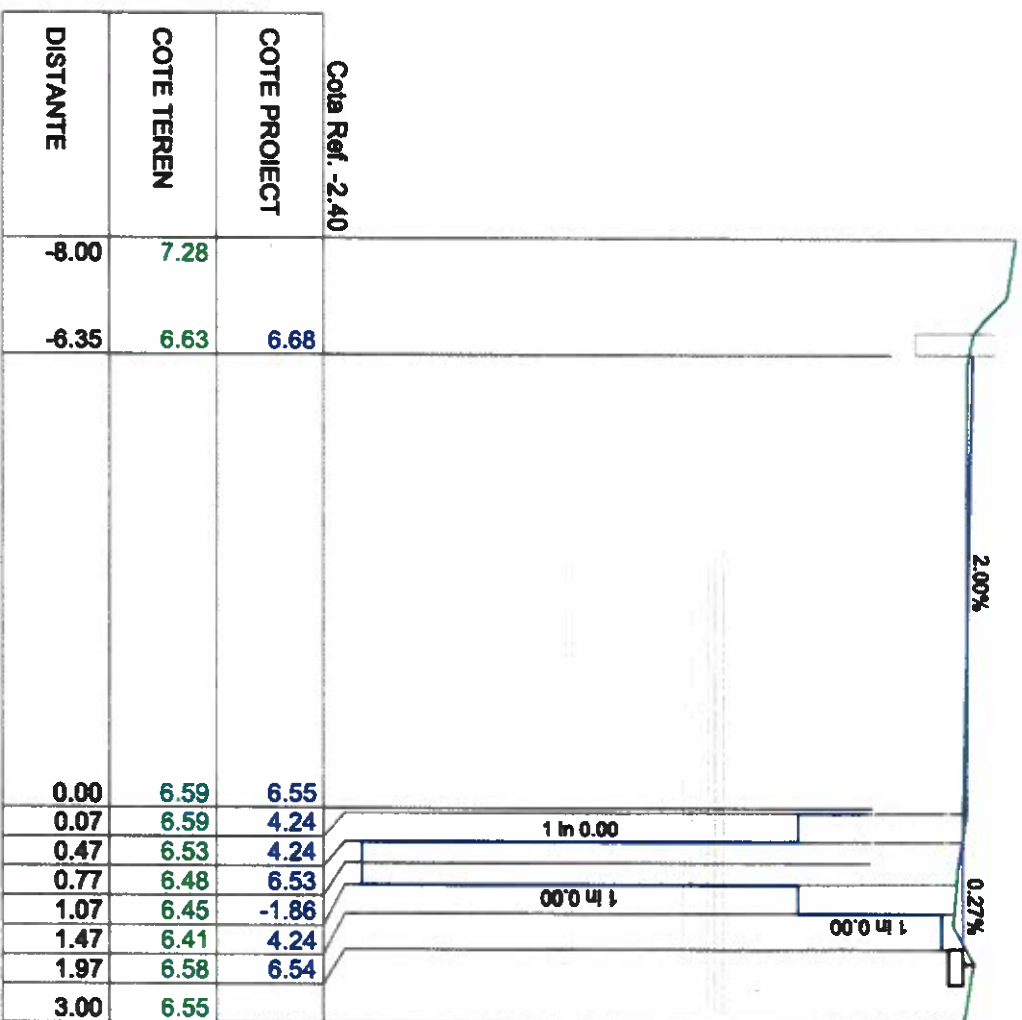
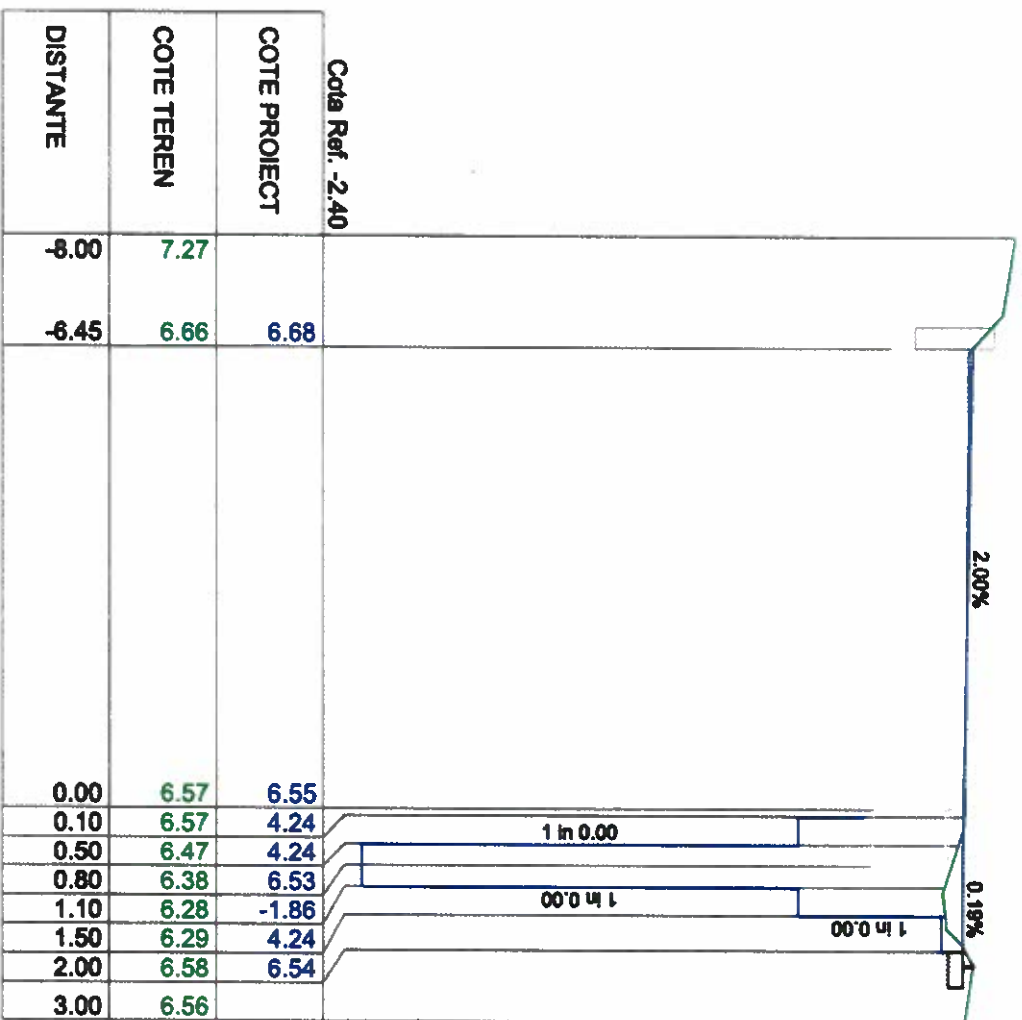

PROIECTANT: S.C. SERVLAND S.R.L. Societate cu raspundabilitate limitata Calea Europei nr. 12, SA, Județul Galati JIT/Inregistrat nr. 180/2018	
BENEFICIAR: S.C. SANTERUL NAVAL DAMEN GALATI S.A.	
DENUMIRE PROIECT: CONSOLIDARE DRUM TEHNOLOGIC IN LUNGUL CHEIULUI, ZONA DANA 1, 2 SI 3	
PROIECTANT	SEMNATURA
DESEINAT	SEMNATURA
DENUMIRE PLANSĂ: PROFILE TRANSVERSAL CARACTERISTICE	
PROIECT NR.:	24/2018
FAZA:	P.A.C.
NR. PLANSĂ:	PL. 5.2
SCARA:	1:100
DATA:	2019

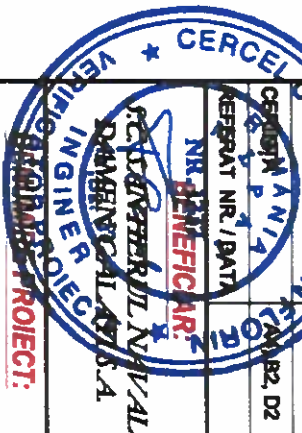

PROIECTANT: S.C. SERVLAND S.R.L. <small>Societate cu Raspundere Limitata</small> <small>Str. Suceava, Nr. 104, Iasi, Romania</small>	
PROIECTANT: Ing. Cristian Eugeniu <small>SEMANTURA</small>	PROIECTANT: Ing. Veronica CerCEL <small>SEMANTURA</small>
PROIECTANT: Ing. Alexandru Vlad-Alexandru <small>SEMANTURA</small>	PROIECTANT: Ing. Alexandru Vlad-Alexandru <small>SEMANTURA</small>
DENUMIRE PLANSĂ: PROFILE TRANSVERSAL CARACTERISTICE	
PROIECT NR.: 24/2018	FAZA: P.A.C.
NR. PLANSĂ: PL. 5.3	SCARA: 1:100
DATA: 2019	

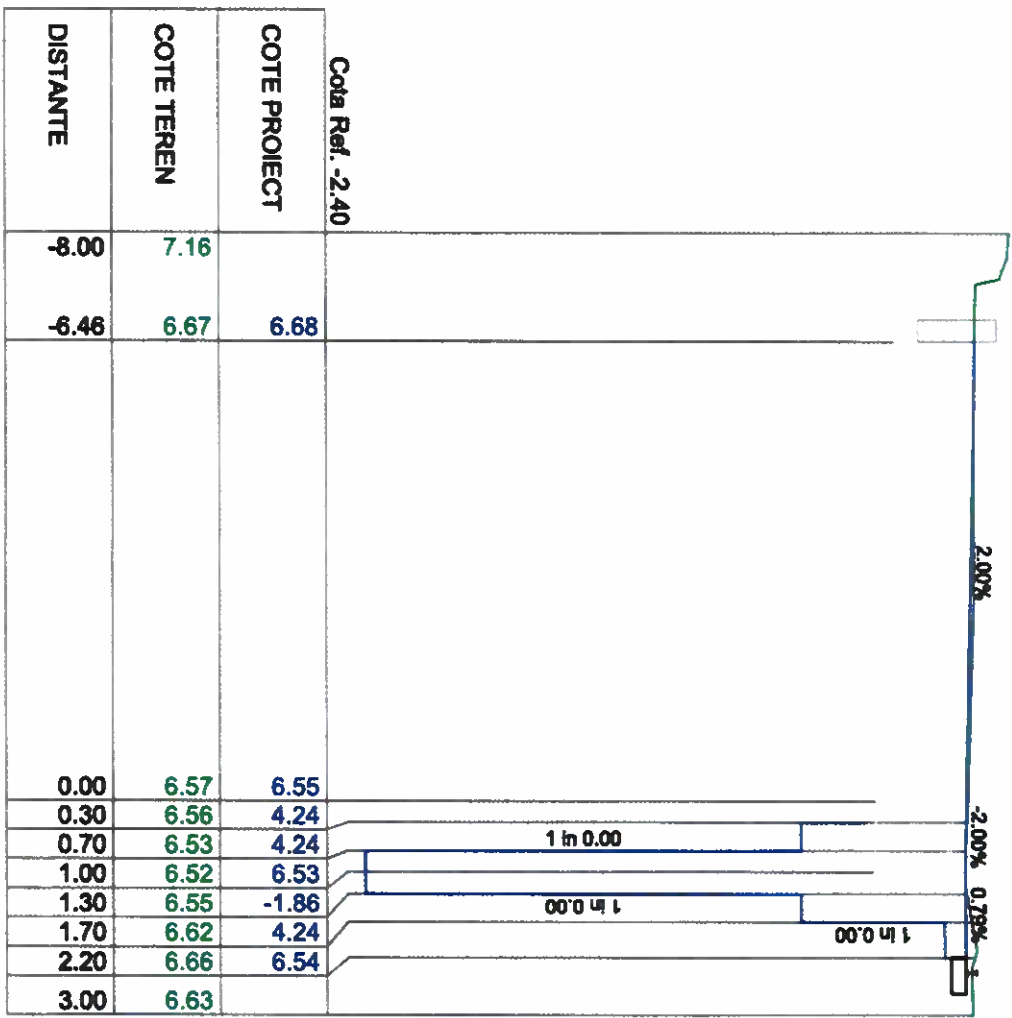
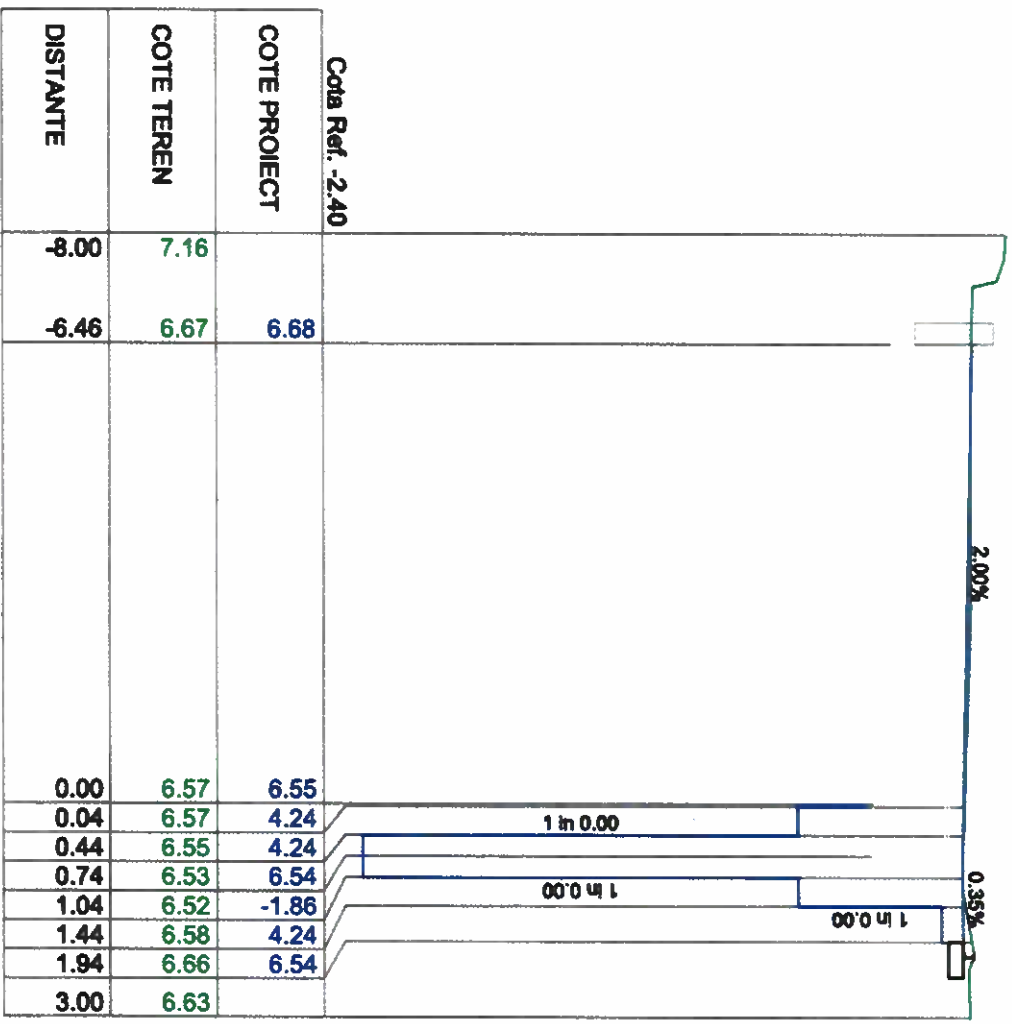

CONSOLIDARE DRUM
TEHNOLOGIC IN
LUNGUL CHEIULUI, ZONA
DANA 1, 2 SI 3

SECȚIUNE A-A

Scara 1:50

F01	Stratificație teren. Foraj geotehnic F1
-2.10m	Strat 1: Umplutură eterogena alcătuită din praf argilos cafeniu, cu intercalatii de caramida, pietris și materie organica, consistenta
-3.10m	Strat 2: Praf argilos cafeniu cu intercalatii de pietris și papusi calcarose, consistent spre varos
-6.10m -6.30m	Strat 3: Complex maios alcătuit din praf argilos și argila de culoare cenusie-negricioasa și rar zone cafenii, cu lentile nisipoase cochlifere decimetrice, varos spre consistent
-7.10m	Strat 4: Praf nisipos argilos cafeniu cu zone cenusii, consistent
-12.00m	Strat 5: Alternanța de praf argilos și argila prafoasa cenusie cu zone cafenii și intercalatii cochlifere, cu lentile centimetrice de praf nisipos, varoasa
	Stratul continuă

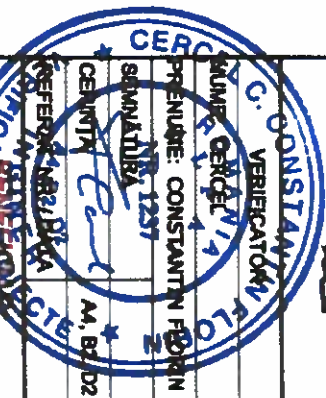
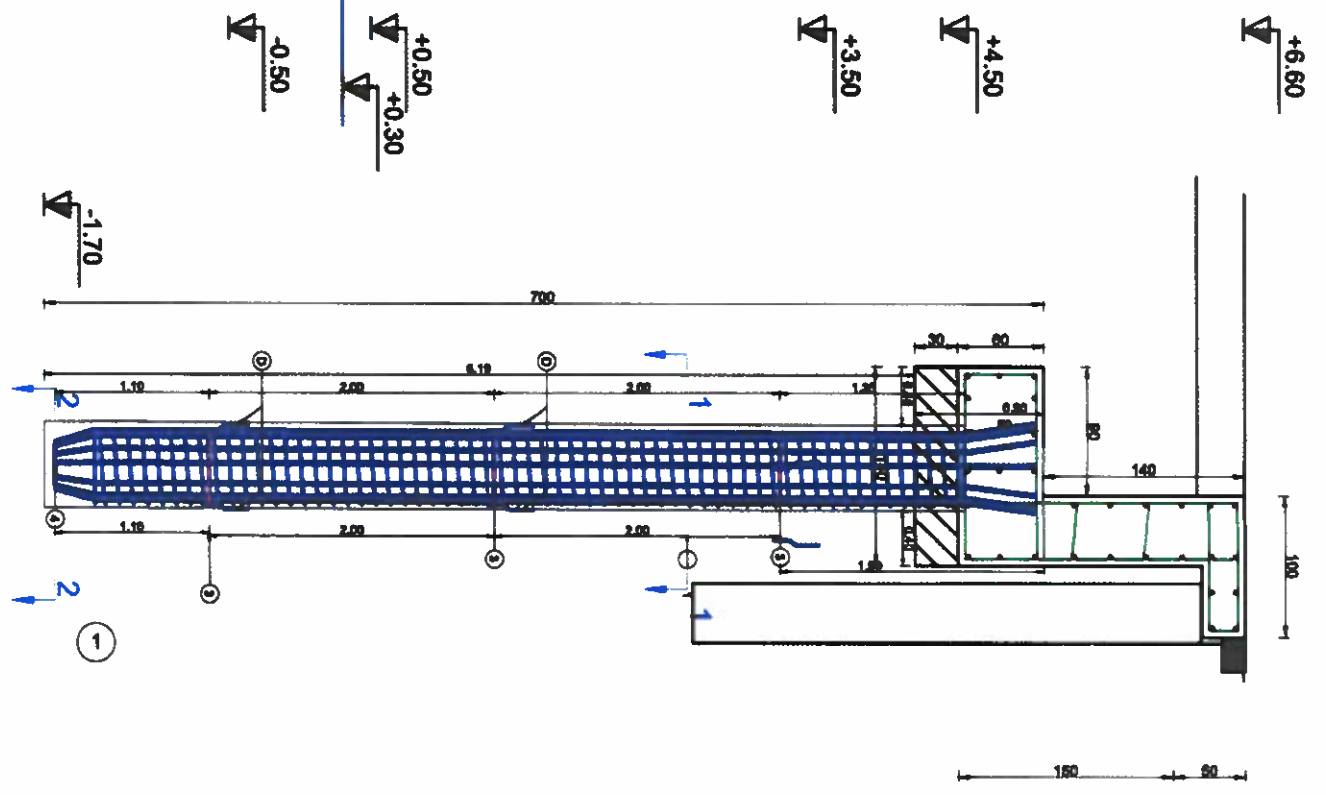

<p>PROIECTANT: S.C. SERVLAND S.R.L. B-Ad Energy Center Nr.104, Județul Lugoj Județul Lugoj - 301000000</p>		<p>DENUMIRE PROIECT: CONSOLIDARE DRUM TEHNOLOGIC IN LUNGUL CHEULUI, ZONA DANA 1, 2 SI 3</p>	
<p>PROIECT: Dr. Ing. Cristian Eugeniu</p>		<p>SEMĂTURĂ: [Signature]</p>	
<p>DESEINAT: Ing. Burzaru Vlad-Alexandru</p>		<p>SEMĂTURĂ: [Signature]</p>	
<p>DENUMIRE PLANȘĂ: DETALIUL ZID DE SPRIJIN</p>			
<p>PROIECT NR.: 24/2018</p>		<p>FAZA: P.A.C.</p>	
<p>NR. PLANȘĂ: PL. 6.0</p>		<p>SCARA: 1:50</p>	
<p>DATA: 2019</p>			

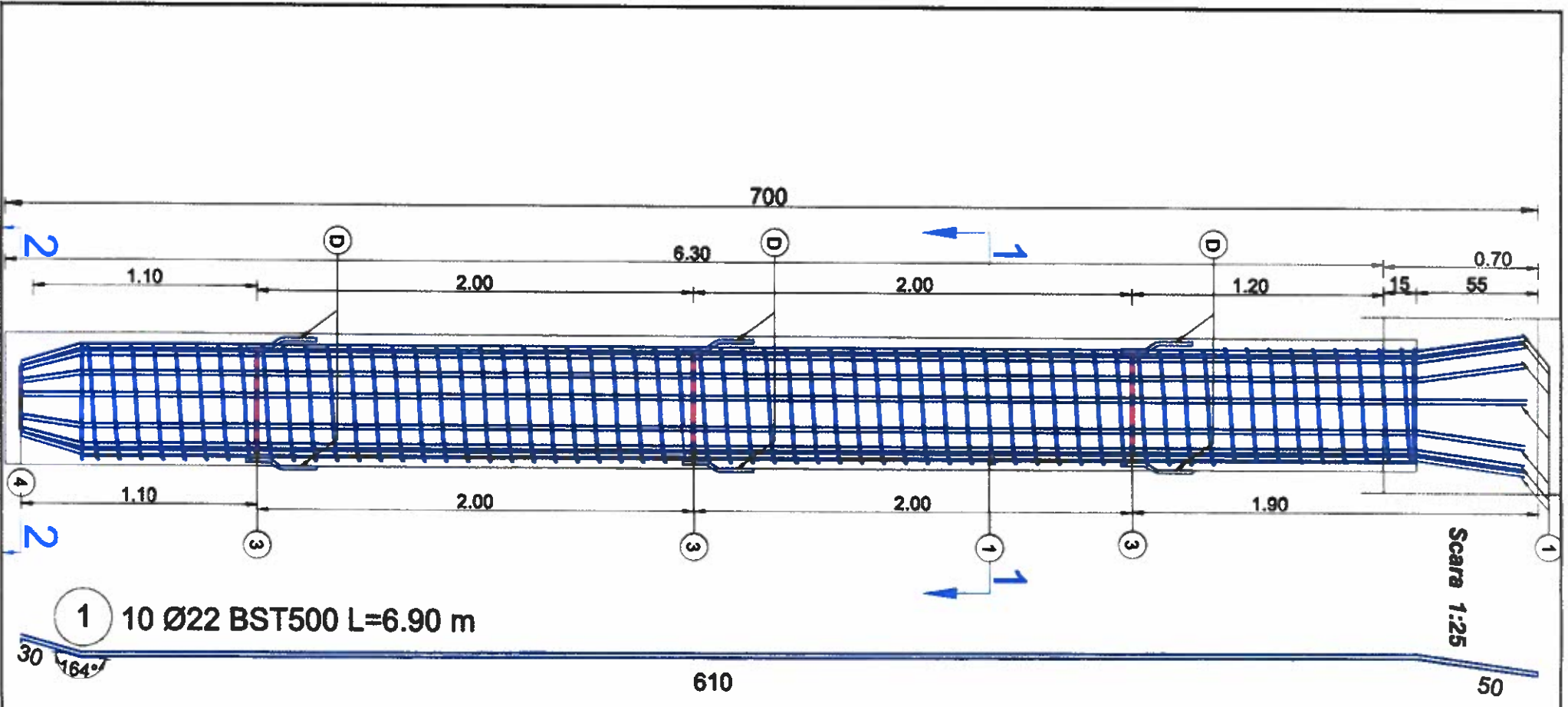

EXTRAS ARMARE PILOT FORAT DIN BETON H=7.0M D=600MM

M	Φ	n	L (m)	LUNGIMI PE DIAMETRE						
				OB37	Φ10	Φ12	Φ16	Φ22	Φ28	
1	22	10	6.90						69.00	
2	22	10	0.00						0.00	
3	16	3	1.45					4.35		
4	16	1	1.10					1.10		
5	10	1	93.05	93.05						
D	16	9	0.35					3.15		
Lungimi totale pe diametre (m)				93.05	0.00	0.00	0.00	8.60	69.00	
Masa pe metru linear (kg/ml)				0.617	0.395	0.617	0.888	1.580	2.982	
Masa pe diametre (kg)				57	0	0	0	14	206	
TOTAL (kg)				OB37	57	PC52		219		
BETON C20/25 /1 ML				L, m	S, mp	V, mc				
1 BETON IN PILOT DE 7M				7	0.2826	1.9782				

SECTIUNE 1-1
Scara 1:20

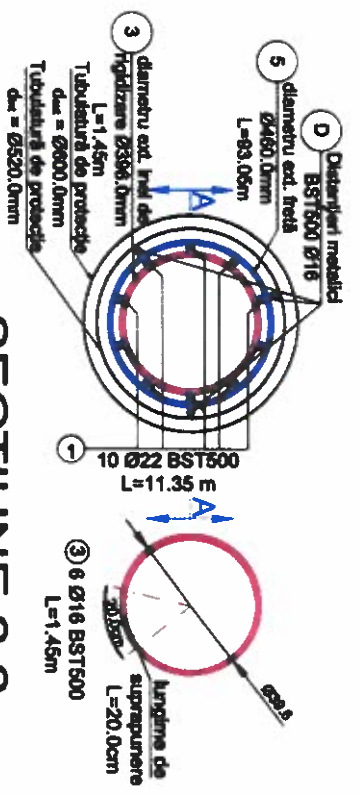

SECTIUNE 2-2
Scara 1:20

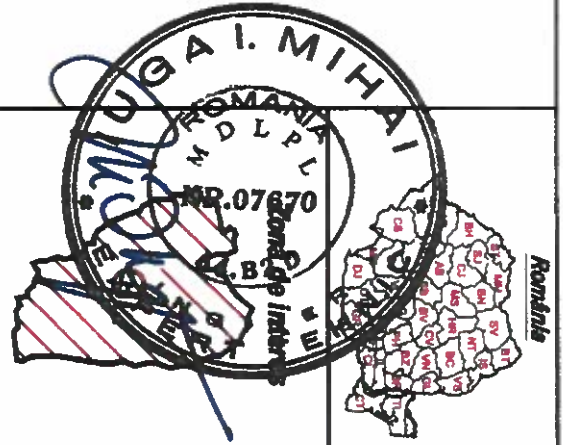
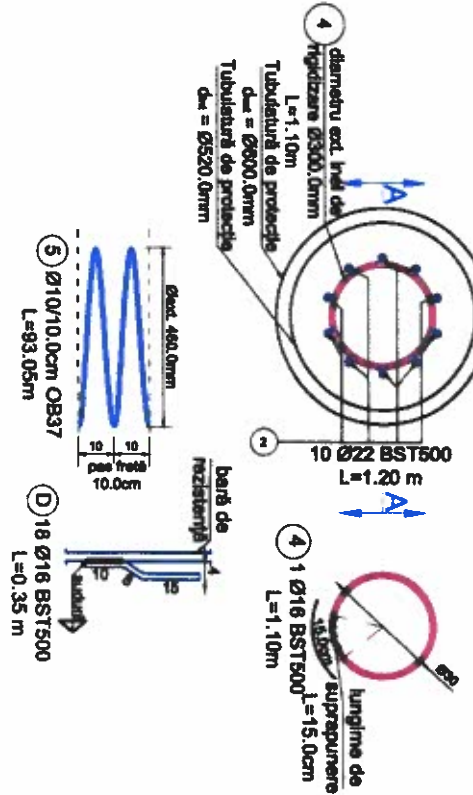

VERIFICATOR
NUME: CERCEL
PROIECTANT
CONSOLIDARE DRUM
TEHNOLOGIC IN
LUNGUL CHEULUI, ZONA
DANA 1, 2 SI 3



PROIECTANT	SEMANTURA
Ing. Mircea Vasilescu	Li
DESEINAT	SEMANTURA
Ing. Mircea Vasilescu	Li
DENUMIRE PLANSA:	
PLAN ARMARE PILOT FORAT	
PROIECT NR.:	24/2018
FAZA:	P.A.C.
NR. PLANSA:	PL. 6.1
SCARA:	1:20-1:25
DATA:	2019

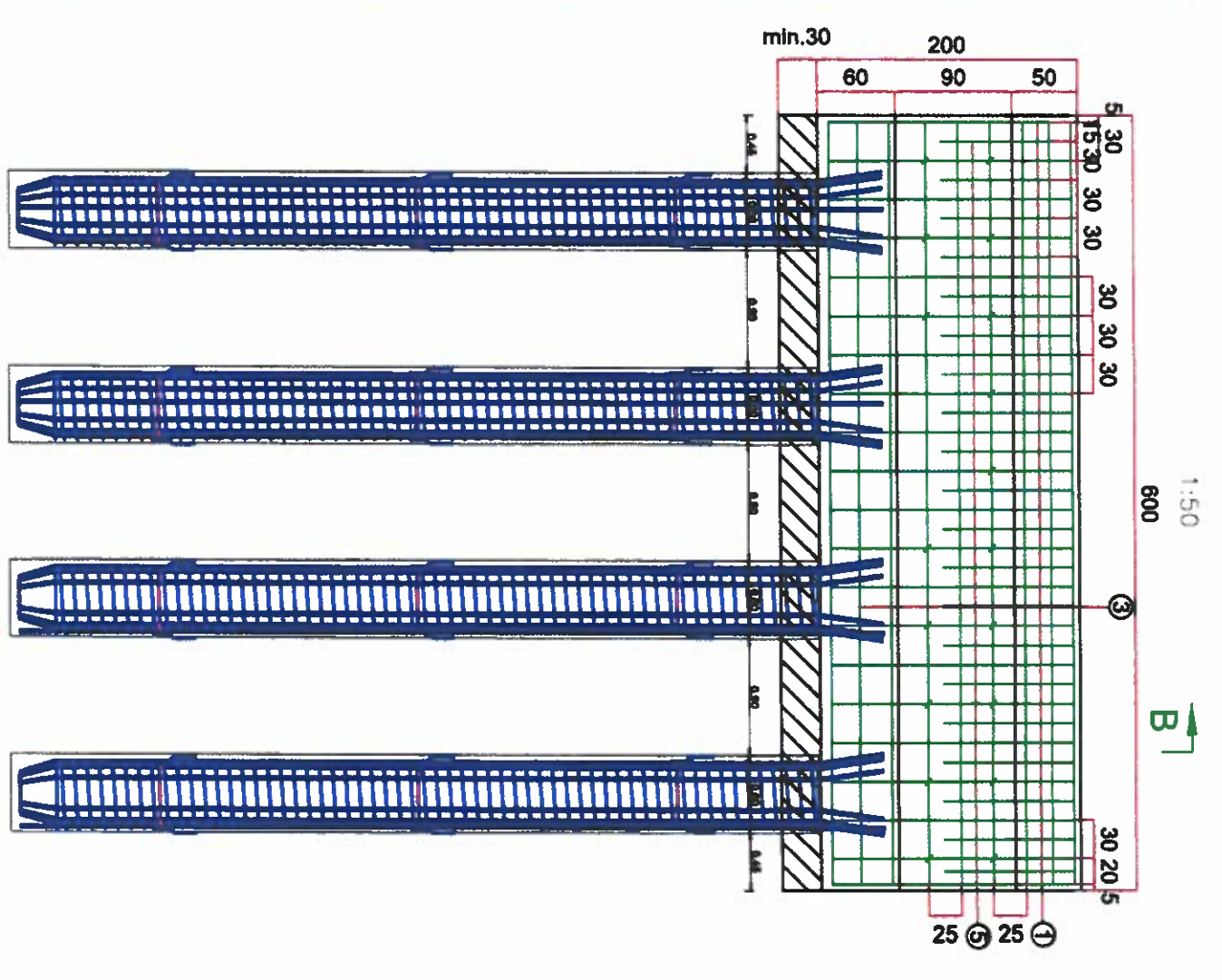

SECTION A-A SECTION 1:50

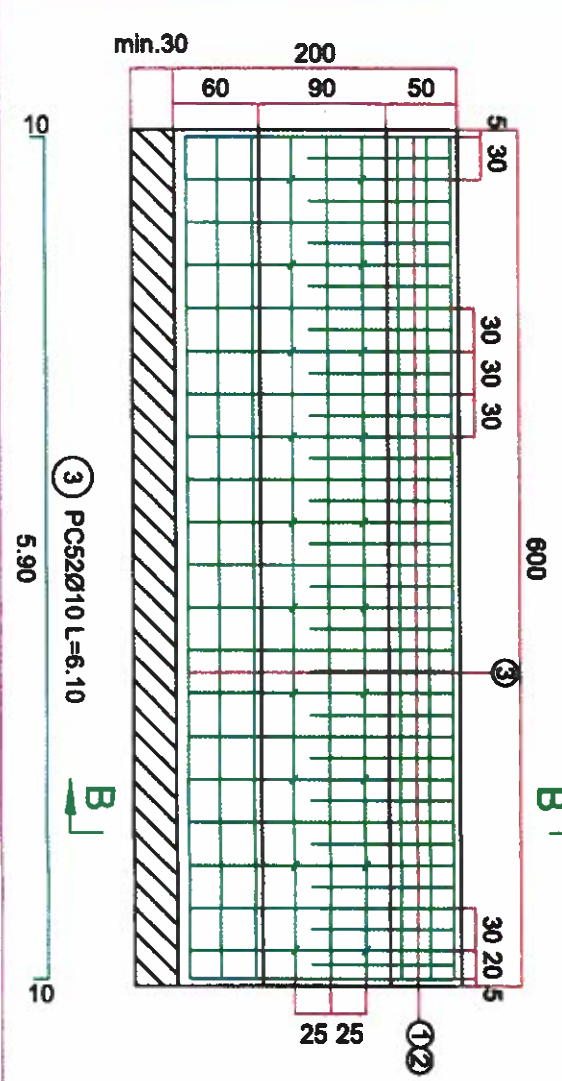

SECTION B-B SECTION 1:50

EXTRAS ARMATURA PENTRU L=6.00 m
REINFORCEMENT TABLE FOR L=6.00 m

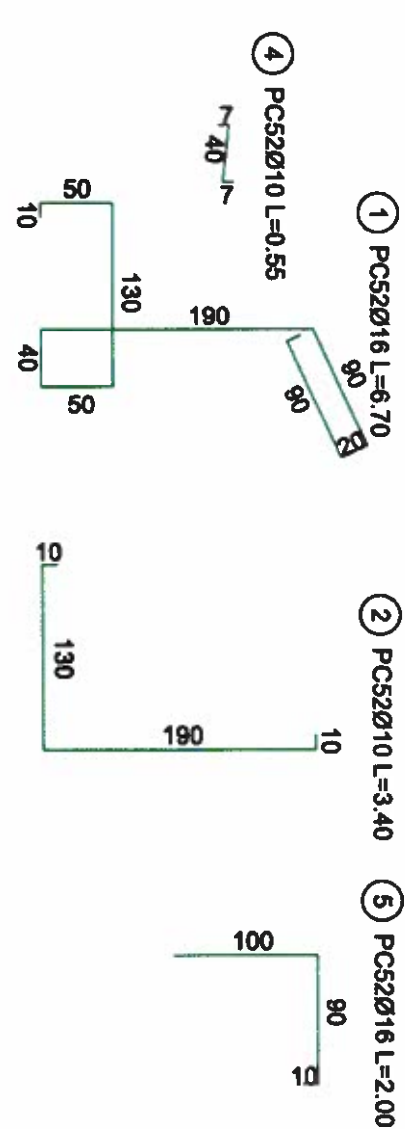

M	Φ	N (buc.)	L (m)	Φ16	Φ12	Φ10
1	16	21	6.20	130.20		71.4
2	10	21	3.40			189.1
3	10	31	6.10			11
4	10	20	0.55			
5	16	20	2.00	40.00	0.00	271.50
total pe diametre (m)				170.20	0.00	0.617
gradati pe diametre (kg/m)				1.578	0.898	0.617
total gradati pe diametre				269	0	169
TOTAL Kg				438		

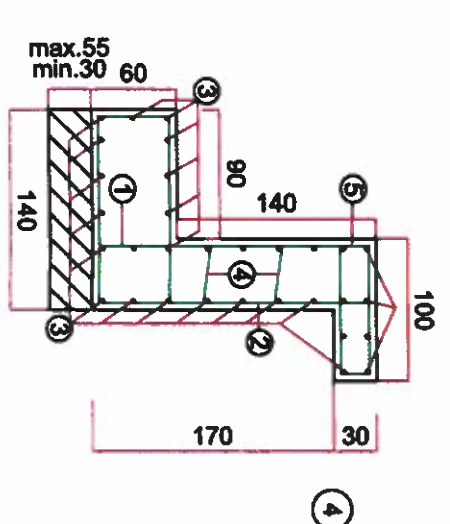

SECTION B-B SECTION 1:50

PROIECTANT:
S.C. SERVLAND S.R.L.
B-dul George Costin B-504
Județul Galati
Strada 14382353
Galati, Romania

PROIECT:
Dr. Ing. Octavian Eugeniu

DESIGNAT:
Ing. Maricela Vasilescu

SEMANTURA:
Ing. Maricela Vasilescu

DESEMANTURA:
Ing. Maricela Vasilescu

DENUMIRE PLANSA:
**PLAN ARMARE ZID
DE SPRIJIN**

PROIECT NR.: 24/2018

FAZA: P.A.C.

NR. PLANSA: PL. G.2

SCARA: 1:50

DATA: 2019

RECEPTOR:
**J.S.C. SANTERUL NAVAL
DAMEN GALATI S.A.**

DENUMIRE PROIECT:
CONSOLIDARE DRUM
TEHNOLOGIC IN
LUNGUL CHEIULUI, ZONA
DANA 1, 2 SI 3

VERIFICATOR:
ING. MARIA-CRISTINA
POPESCU

PROIECTANT:
ING. MARICELA VASILESCU

SEMANTURA:
ING. MARICELA VASILESCU

DESEMANTURA:
ING. MARICELA VASILESCU

PROIECTANT:
ING. MARICELA VASILESCU

SEMANTURA:
ING. MARICELA VASILESCU

DESEMANTURA:
ING. MARICELA VASILESCU